

NOTE 1:

(1) FOR SEG RSV34-MS1 RESOLVER, JUMPER R0 TO R1 ON RESOLVER INPUT.

(2) FOR AUTOTECH RESOLVERS, INSTALL 47ohm, 1/2W RESISTOR BETWEEN R0 AND R1 ON RESOLVER INPUT.

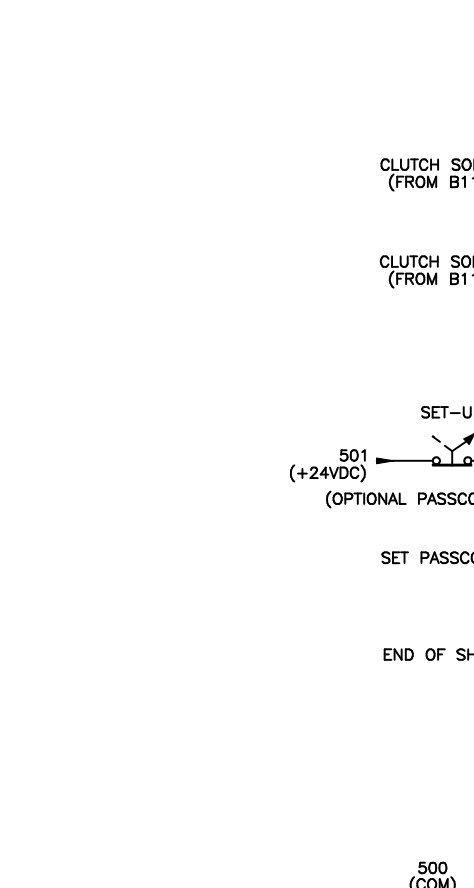
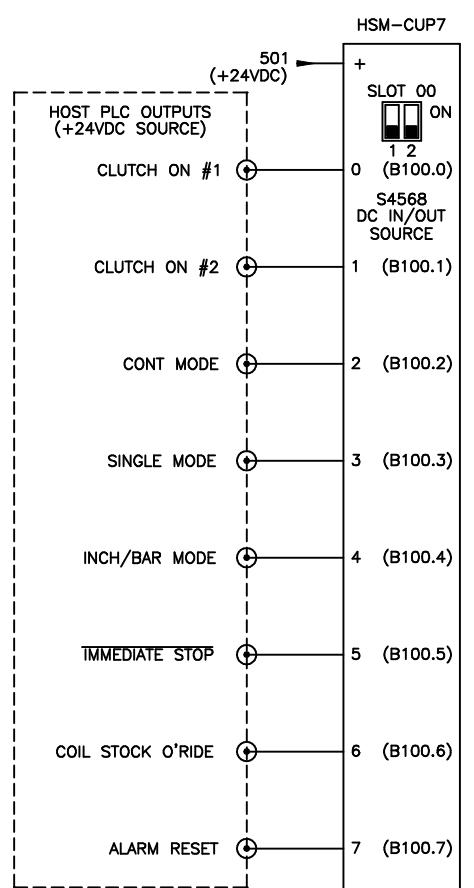
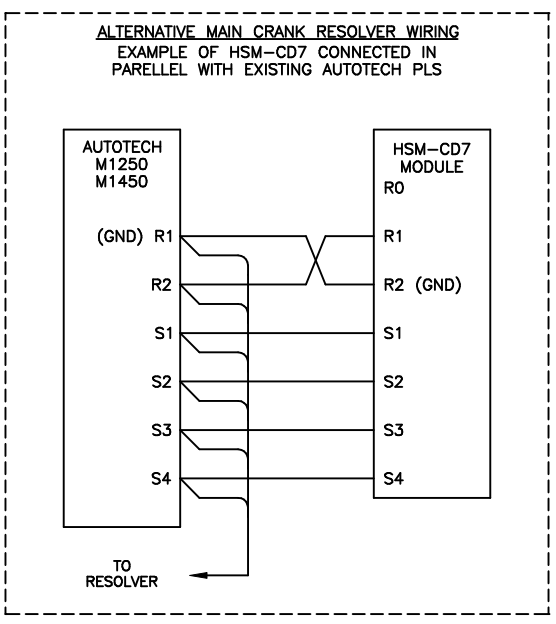

STATION NUMBER OF FAULT DECODE:

B3	B2	B1	B0	STATION NUMBER
0	0	0	0	1
0	0	0	1	2
0	0	1	0	3
0	0	1	1	4
0	1	0	0	5
0	1	0	1	6
0	1	1	0	7
0	1	1	1	8
1	0	0	0	9
1	0	0	1	10
1	0	1	0	11
1	0	1	1	12
1	1	0	0	13
1	1	0	1	14
1	1	1	0	15
1	1	1	1	16

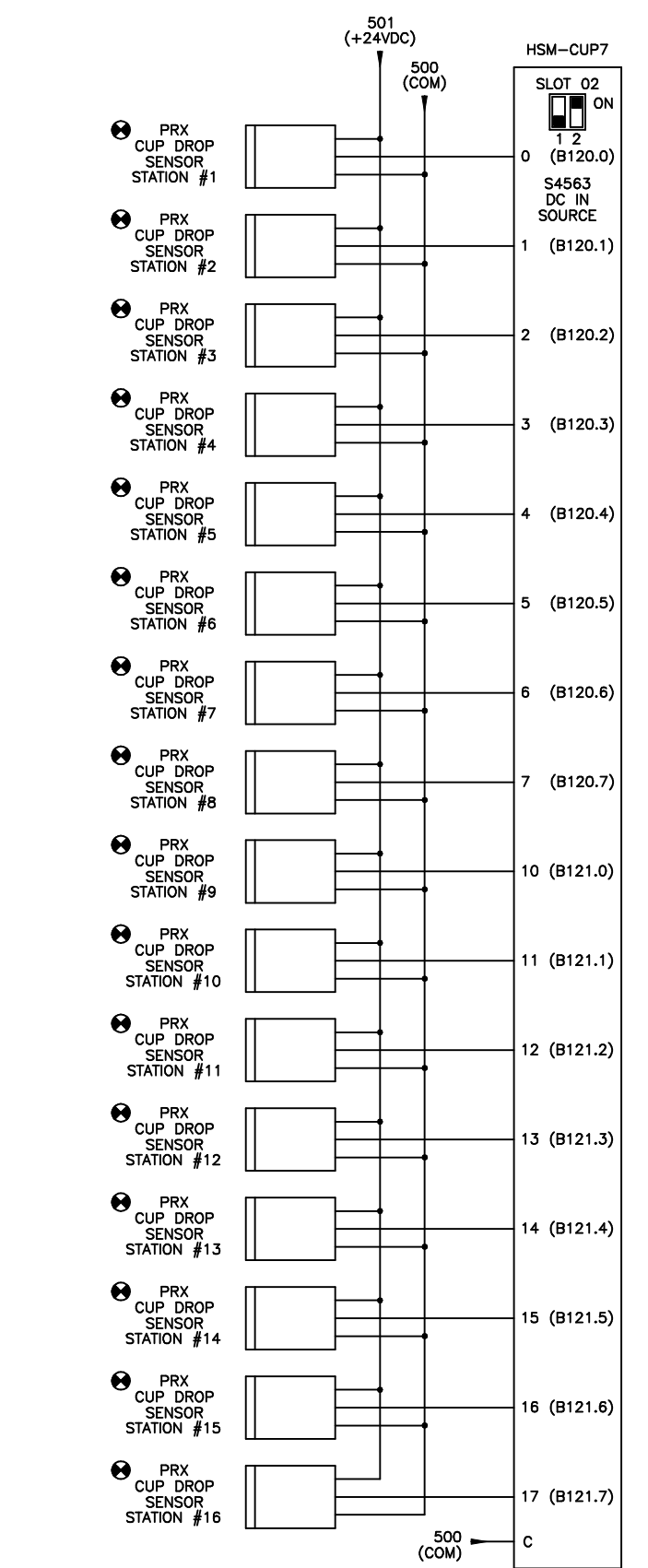
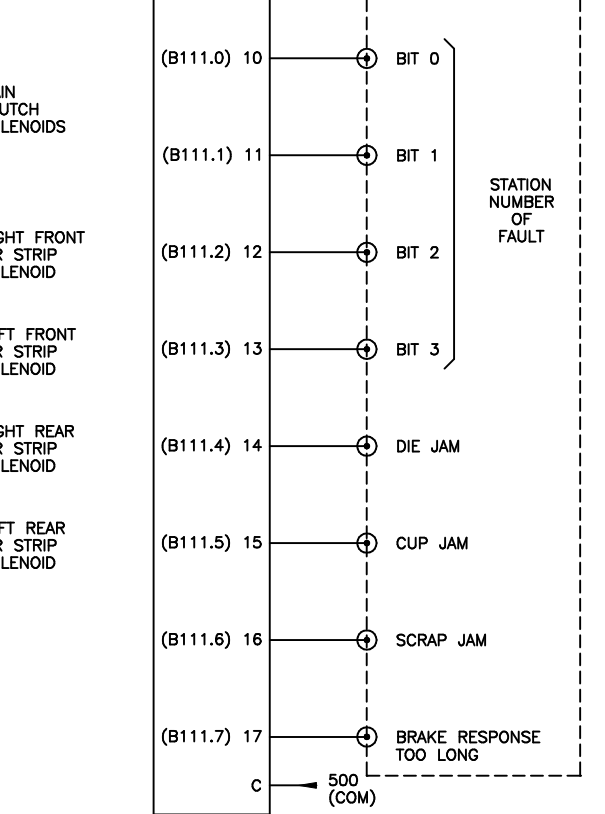
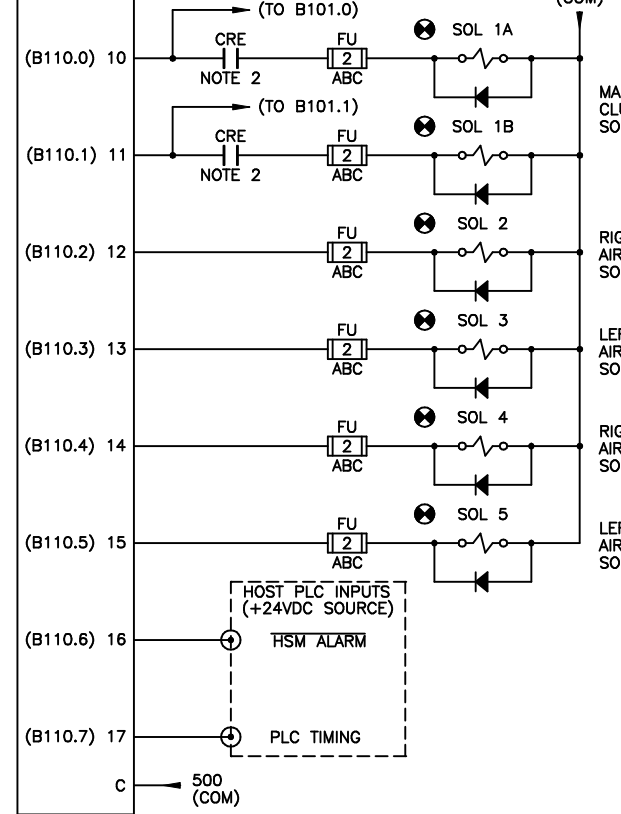

- HSM ALARM SUMMATION:**
- 1) COIL STOCK O'RIDE MODE FAULT
 - 2) TIMING SIGNAL FAIL
 - 3) CLUTCH OUTPUT NO.1 FAIL
 - 4) CLUTCH OUTPUT NO.2 FAIL
 - 5) NO RAM MOTION DETECTED
 - 6) RESOLVER FAULT (MOTION DETECTED WHEN STOPPED)

NOTE 2:

IMPORTANT SAFETY WARNING!
THE HSM-CUP7 IS INTENDED AS A HIGH-SPEED LOGIC GATE TO PROVIDE CONSISTENT AND ACCURATE CLUTCH CONTROL. IT IS NOT DESIGNED AS A REDUNDANT, DUAL-PROCESSOR CLUTCH BRAKE SAFETY MODULE.

THE HSM-CUP7 MUST NOT BE THE ONLY MEANS OF CONTROLLING THE CUPPER CLUTCH MECHANISM. GOOD DESIGN PRACTICE DICTATES THE USE OF SAFETY INTERLOCKS ON ANY DEVICE THAT STARTS OR STOPS AUTOMATICALLY THAT CAN CAUSE PERSONNEL INJURY TO OPERATING OR MAINTENANCE PERSONNEL.

THE HSM-CUP7 MUST BE USED ONLY IN CONJUNCTION WITH INDUSTRY APPROVED SAFETY INTERLOCK CONTACTS, IMPLEMENTED IN ACCORDANCE WITH ANSI B11.1 SAFETY REQUIREMENTS; OTHERWISE, SERIOUS PERSONNEL INJURY MAY RESULT.

CONFIDENTIAL
This document is the property of Systems Engineering Associates, Inc. The information contained herein is to be reproduced, copied or disclosed to others. Drawing to be returned upon request.

SYSTEMS ENGINEERING ASSOCIATES, INC.
ARVADA, COLORADO

SCALE: 9-10-97
APPROVED:
DATE: 9-10-97

DRAWN BY: KDV
REVISED: 2-20-04

HSM-CUP7
ELECTRICAL CONTROL SCHEMATIC

SYSTEMS ELECTRONICS GROUP

WO#
PT#
DRAWING NUMBER
14-4102-10

